

Valvola 3010 con
pam 800 + vsma
3010 valve block
with hand pump
+ vsma

Vite spurgo
aria pam
Air bleeder
screw for pam

Valvola 3010 con
piastra P 81
3010 valve block
with P81 hand pump
+ vsma plate

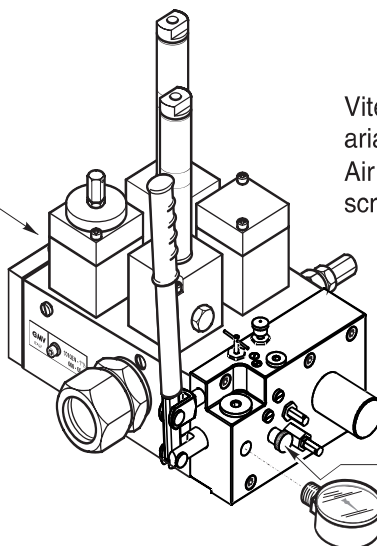

Vite spurgo
aria pam
Air bleeder
screw for pam

(*) pam = hand pump (*) ST= star delta starting

descrizione	description	codice / code
valvola 3010 1"¼ l/min 35	3010 valve 1"¼ l/min 35	R8 0300 002
valvola 3010 1"¼ l/min 35 PAM	3010 valve 1"¼ l/min 35 PAM*	R8 0300 003
valvola 3010 1"¼ l/min 35 P81	3010 valve 1"¼ l/min 35 P81	R8 0300 022
valvola 3010 1"¼ l/min 35 ST	3010 valve 1"¼ l/min 35 ST	R8 0300 004
valv. 3010 1"¼ l/min 35 ST PAM	3010 valve 1"¼ l/min 35 ST PAM*	R8 0300 005
valv. 3010 1"¼ l/min 35 ST P81	3010 valve 1"¼ l/min 35 ST P81	R8 0300 023
valvola 3010 1"¼ l/min 42 ÷ 75	3010 valve 1"¼ l/min 42 ÷ 75	R8 0300 006
valvola 3010 1"¼ l/min 42 ÷ 75 PAM	3010 valve 1"¼ l/min 42 ÷ 75 PAM*	R8 0300 007
valvola 3010 1"¼ l/min 42 ÷ 75 P81	3010 valve 1"¼ l/min 42 ÷ 75 P81	R8 0300 024
valvola 3010 1"¼ l/min 42 ÷ 75 ST	3010 valve 1"¼ l/min 42 ÷ 75 ST	R8 0300 008
valvola 3010 1"¼ l/min 42 ÷ 75 ST PAM	3010 valve 1"¼ l/min 42 ÷ 75 ST PAM*	R8 0300 009
valvola 3010 1"¼ l/min 42 ÷ 75 ST P81	3010 valve 1"¼ l/min 42 ÷ 75 ST P81	R8 0300 025
valvola 3010 1"¼ l/min 90 ÷ 150	3010 valve 1"¼ l/min 90 ÷ 150	R8 0300 010
valvola 3010 1"¼ l/min 90 ÷ 150 PAM	3010 valve 1"¼ l/min 90 ÷ 150 PAM*	R8 0300 011

descrizione	description	codice / code
valvola 3010 1"¼ l/min 90 ÷ 150 P81	3010 valve 1"¼ l/min 90 ÷ 150 P81	R8 0300 026
valvola 3010 1"¼ l/min 90 ÷ 150 ST	3010 valve 1"¼ l/min 90 ÷ 150 ST	R8 0300 012
valvola 3010 1"¼ l/min 90 ÷ 150 ST PAM	3010 valve 1"¼ l/min 90 ÷ 150 ST PAM*	R8 0300 013
valvola 3010 1"¼ l/min 90 ÷ 150 ST P81	3010 valve 1"¼ l/min 90 ÷ 150 ST P81	R8 0300 027
valvola 3010 1"¼ l/min 180 ÷ 216	3010 valve 1"¼ l/min 180 ÷ 216	R8 0300 014
valvola 3010 1"¼ l/min 180 ÷ 216 PAM	3010 valve 1"¼ l/min 180 ÷ 216 PAM*	R8 0300 015
valvola 3010 1"¼ l/min 180 ÷ 216 P81	3010 valve 1"¼ l/min 180 ÷ 216 P81	R8 0300 028
valvola 3010 1"¼ l/min 180 ÷ 216 ST	3010 valve 1"¼ l/min 180 ÷ 216 ST	R8 0300 016
valv. 3010 1"¼ l/min 180 ÷ 216 ST PAM	3010 valve 1"¼ l/min 180 ÷ 216 ST PAM*	R8 0300 017
valv. 3010 1"¼ l/min 180 ÷ 216 ST P81	3010 valve 1"¼ l/min 180 ÷ 216 ST P81	R8 0300 029
valv.30101"¼ l/m180÷216 STPAM VR2	3010 valve 1"¼ l/min180÷216 ST PAM* vr2	R8 0300 054
valvola 3010 1"½ l/min 180 ÷ 216	3010 valve 1"½ l/min 180 ÷ 216	R8 0303 001
valvola 3010 1"½ l/min180 ÷ 216 PAM	3010 valve 1"½ l/min 180 ÷ 216 PAM*	R8 0303 002
valvola 3010 1"½ l/min 180 ÷ 216 P81	3010 valve 1"½ l/min 180 ÷ 216 P81	R8 0303 018
valvola 3010 1"½ l/min 180 ÷ 216 ST	3010 valve 1"½ l/min 180 ÷ 216 ST	R8 0303 003
valv. 3010 1"½ l/min180 ÷ 216 ST PAM	3010 valve 1"½ l/min 180 ÷ 216 ST PAM*	R8 0303 004
valv. 3010 1"½ l/min180 ÷ 216 ST P81	3010 valve 1"½ l/min 180 ÷ 216 ST P81	R8 0303 019
valvola 3010 1"½ l/min 250 ÷ 360	3010 valve 1"½ l/min 250 ÷ 360	R8 0303 005
valvola 3010 1"½ l/min 250 ÷ 360 PAM	3010 valve 1"½ l/min 250 ÷ 360 PAM*	R8 0303 006
valvola 3010 1"½ l/min 250 ÷ 360 P81	3010 valve 1"½ l/min 250 ÷ 360 P81	R8 0303 020
valvola 3010 1"½ l/min 250 ÷ 360 ST	3010 valve 1"½ l/min 250 ÷ 360 ST	R8 0303 007
valv. 3010 1"½ l/min 250 ÷ 360 ST PAM	3010 valve 1"½ l/min 250 ÷ 360 ST PAM*	R8 0303 008
valv. 3010 1"½ l/min 250 ÷ 360 ST P81	3010 valve 1"½ l/min 250 ÷ 360 ST P81	R8 0303 021
valv. 3010 1"½ l/min 430 ÷ 432 ST P81	3010 valve 1"½ l/min 430 ÷ 432 ST P81	R8 0303 009
valvola 3010 1"½ l/min 430 ÷ 432 PAM	3010 valve 1"½ l/min 430 ÷ 432 PAM*	R8 0303 010
valvola 3010 1"½ l/min 430 ÷ 432 P81	3010 valve 1"½ l/min 430 ÷ 432 P81	R8 0303 022
valvola 3010 1"½ l/min 430 ÷ 432 ST	3010 valve 1"½ l/min 430 ÷ 432 ST	R8 0303 011
valv. 3010 1"½ l/min 430 ÷ 432 ST PAM	3010 valve 1"½ l/min 430 ÷ 432 ST PAM*	R8 0303 012
valv. 3010 1"½ l/min 430 ÷ 432 ST P81	3010 valve 1"½ l/min 430 ÷ 432 ST P81	R8 0303 023
valvola 3010 2" l/min 600	3010 valve 2" l/min 600	R8 0306 001
valvola 3010 2" l/min 600 PAM	3010 valve 2" l/min 600 PAM*	R8 0306 002
valvola 3010 2" l/min 600 ST	3010 valve 2" l/min 600 ST	R8 0306 003
valvola 3010 2" l/min 600 ST PAM	3010 valve 2" l/min 600 ST PAM*	R8 0306 004
valvola 3010 2" l/min 600 ST VR2	3010 valve 2" l/min 600 ST VR2	R8 0306 014

(*) pam = and pump

descrizione	description	codice / code
valvola 3010 1"¼ l/min 55 ÷ 75 soft pam	3010 valve 1"¼ l/min 55 ÷ 75 soft pam*	R8 0300 056
valv. 3010 1"¼ l/min 35 fino 37 soft pam	3010 valve 1"¼ l/min 35 till 37 soft pam*	R8 0300 062
valvola 3010 1"¼ l/min 100 soft- stop pam	3010 valve 1"¼ l/min 100 soft- stop pam*	R8 0300 057
valvola 3010 1"¼ l/min 125 soft- stop pam	3010 valve 1"¼ l/min 125 soft- stop pam*	R8 0300 058
valvola 3010 1"¼ l/min 150 soft- stop pam	3010 valve 1"¼ l/min 150 soft- stop pam*	R8 0300 059
valvola 3010 1"¼ l/min 180 soft- stop pam	3010 valve 1"¼ l/min 180 soft- stop pam*	R8 0300 060
valvola 3010 1"¼ l/min 210 soft- stop pam	3010 valve 1"¼ l/min 210 soft- stop pam*	R8 0300 061
valv. 3010 1"½ l/min 210 soft- stop pam	3010 valve 1"½ l/min 210 soft- stop pam*	R8 0303 045
valvola 3010 1"½ l/min 250 soft- stop pam	3010 valve 1"½ l/min 250 soft- stop pam*	R8 0303 046
valvola 3010 1"½ l/min 300 soft- stop pam	3010 valve 1"½ l/min 300 soft- stop pam*	R8 0303 047
valvola 3010 1"½ l/min 360 soft- stop pam	3010 valve 1"½ l/min 360 soft- stop pam*	R8 0303 048
valvola 3010 1"½ l/min 430 soft- stop pam	3010 valve 1"½ l/min 430 soft- stop pam*	R8 0303 049
valvola 3010 2" l/min 430 soft- stop pam	3010 valve 2" l/min 430 soft- stop pam*	R8 0306 015
valvola 3010 2" l/min 500 soft- stop pam	3010 valve 2" l/min 500 soft- stop pam*	R8 0306 016
valvola 3010 2" l/min 600 soft- stop pam	3010 valve 2" l/min 600 soft- stop pam*	R8 0306 017
valv. 3010 1"¼ fino 37 l/min soft- stop P81	3010 valve 1"¼ l/min 37 till soft- stop P81	R8 0300 071
valv. 3010 1"¼ 42-75 l/min soft- stop P81	3010 valve 1"¼ l/min 42-75 soft- stop P81	R8 0300 065
valv. 3010 1"¼ 100 l/min soft- stop P81	3010 valve 1"¼ l/min 100 soft- stop P81	R8 0300 066
valv. 3010 1"¼ 125 l/min soft- stop P81	3010 valve 1"¼ l/min 125 soft- stop P81	R8 0300 067
valv. 3010 1"¼ 150 l/min soft- stop P81	3010 valve 1"¼ l/min 150 soft- stop P81	R8 0300 068
valv. 3010 1"¼ 180 l/min soft- stop P81	3010 valve 1"¼ l/min 180 soft- stop P81	R8 0300 069
valv. 3010 1"¼ 210 l/min soft- stop P81	3010 valve 1"¼ l/min 210 soft- stop P81	R8 0300 070
valv. 3010 1"¼ fino 37 l/min 2chS P81	3010 valve 1"¼ l/min 37 till 2chS P81	R8 0300 072
valv. 3010 1"¼ 42-75 l/min 2chS P81	3010 valve 1"¼ l/min 42-75 2chS P81	R8 0300 073
valv. 3010 1"¼ 100 l/min 2chS P81	3010 valve 1"¼ l/min 100 2chS P81	R8 0300 074
valv. 3010 1"¼ 125 l/min 2chS P81	3010 valve 1"¼ l/min 125 2chS P81	R8 0300 075
valv. 3010 1"¼ 150 l/min 2chS P81	3010 valve 1"¼ l/min 150 2chS P81	R8 0300 076
valv. 3010 1"¼ 180 l/min 2chS P81	3010 valve 1"¼ l/min 180 2chS P81	R8 0300 077
valv. 3010 1"¼ 210 l/min 2chS P81	3010 valve 1"¼ l/min 210 2chS P81	R8 0300 078
valv. 3010 1"¼ 37 l/min 2ch P81	3010 valve 1"¼ l/min 37 2ch P81	R8 0300 087
valv. 3010 1"¼ 42-75 l/min 2ch P81	3010 valve 1"¼ l/min 42-75 2ch P81	R8 0300 088
valv. 3010 1"¼ 90-150 l/min 2ch P81	3010 valve 1"¼ l/min 90-150 2ch P81	R8 0300 089
valv. 3010 1"¼ 180-216 l/min 2ch P81	3010 valve 1"¼ l/min 180-216 2ch P81	R8 0300 090

(*) pam = and pump

descrizione	description	codice / code
valv. 3010 1"¼ fino 37 l/min sof-S PAM	3010 valve 1"¼ l/min 37 till soft-S PAM	R8 0300 062
valv. 3010 1"½ 210 l/min sof-S P81	3010 valve 1"½ 210 l/min soft-S P81	R8 0303 052
valv. 3010 1"½ 250 l/min sof-S P81	3010 valve 1"½ l/min 250 soft-S P81	R8 0303 053
valv. 3010 1"½ 300 l/min sof-S P81	3010 valve 1"½ l/min 300 soft-S P81	R8 0303 054
valv. 3010 1"½ 360 l/min sof-S P81	3010 valve 1"½ l/min 360 soft-S P81	R8 0303 055
valv. 3010 1"½ 430 l/min sof-S P81	3010 valve 1"½ l/min 430 soft-S P81	R8 0303 056
valv. 3010 1"½ 210 l/min 2chS P81	3010 valve 1"½ l/min 210 2chS P81	R8 0303 057
valv. 3010 1"½ 250 l/min 2chS P81	3010 valve 1"½ l/min 250 2chS P81	R8 0303 058
valv. 3010 1"½ 300 l/min 2chS P81	3010 valve 1"½ l/min 300 2chS P81	R8 0303 059
valv. 3010 1"½ 360 l/min 2chS P81	3010 valve 1"½ l/min 360 2chS P81	R8 0303 060
valv. 3010 1"½ 430 l/min 2chS P81	3010 valve 1"½ l/min 430 2chS P81	R8 0303 061
valv. 3010 1"½ 180-216 l/min 2ch P81	3010 valv. 1"½ l/min 180-216 2ch P81	R8 0303 062
valv. 3010 1"½ 250-360 l/min 2ch P81	3010 valve 1"½ l/min 250-360 2ch P81	R8 0303 063
valv. 3010 1"½ 430-432 l/min 2ch P81	3010 valve 1"½ l/min 430-432 2ch P81	R8 0303 064
valv. 3010 2" 430 l/min soft-S PAM	3010 valve 2" l/min 430 soft-S PAM	R8 0306 015
valv. 3010 2" 500 l/min soft-S PAM	3010 valve 2" l/min 500 soft-S PAM	R8 0306 016
valv. 3010 2" 600 l/min soft-S PAM	3010 valve 2" l/min 600 soft-S PAM	R8 0306 017
valv. 3010 2" 600 l/min 2chS PAM	3010 valve 2" l/min 600 2chS PAM	R8 0306 019
valv. 3010 2" 430 l/min 2chS PAM	3010 valve 2" l/min 430 2chS PAM	R8 0306 020
valv. 3010 2" 500 l/min 2chS PAM	3010 valve 2" l/min 500 2chS PAM	R8 0306 021
valv. 3010 2" 600 l/min 2ch PAM	3010 valve 2" l/min 600 2ch PAM	R8 0306 022
valv. 3010 1"¼ 37 l/min SOFT-STOP	3010 valve 1"¼ l/min 37 SOFT-STOP	R8 0300 091
valv. 3010 1"¼ 42/75 l/min SOFT-STOP	3010 valve 1"¼ l/min 42/75 SOFT-STOP	R8 0300 092
valv. 3010 1"¼ 90/100 l/min SOFT-STOP	3010 valve 1"¼ l/min 90/100 SOFT-STOP	R8 0300 093
valv. 3010 1"¼ 120/125 l/min SOFT-STOP	3010 valve 1"¼ l/min 120/125 SOFT-STOP	R8 0300 094
valv. 3010 1"¼ 150 l/min SOFT-STOP	3010 valve 1"¼ l/min 150 SOFT-STOP	R8 0300 095
valv. 3010 1"¼ 180 l/min SOFT-STOP	3010 valve 1"¼ l/min 180 SOFT-STOP	R8 0300 096
valv. 3010 1"¼ 210/216 l/min SOFT-STOP	3010 valve 1"¼ l/min 210/216 SOFT-STOP	R8 0300 097
valv. 3010 1"½ 180/216 l/min SOFT-STOP	3010 valve 1"½ l/min 180/216 SOFT-STOP	R8 0303 065
valv. 3010 1"½ 250/252 l/min SOFT-STOP	3010 valve 1"½ l/min 250/252 SOFT-STOP	R8 0303 066
valv. 3010 1"½ 300 l/min SOFT-STOP	3010 valve 1"½ l/min 300 SOFT-STOP	R8 0303 067
valv. 3010 1"½ 360 l/min SOFT-STOP	3010 valve 1"½ l/min 360 SOFT-STOP	R8 0303 068
valv. 3010 1"½ 430/432 l/min SOFT-STOP	3010 valve 1"½ l/min 430/432 SOFT-STOP	R8 0303 069
valv. 3010 2" 430/432 l/min SOFT-STOP	3010 valve 2" l/min 430/432 SOFT-STOP	R8 0306 023
valv. 3010 2" 500/516 l/min SOFT-STOP	3010 valve 2" l/min 500/516 SOFT-STOP	R8 0306 024
valv. 3010 2" 600 l/min SOFT-STOP	3010 valve 2" l/min 600 SOFT-STOP	R8 0306 025